

**INSTANT MATCH<sup>®</sup>**  
premium



## INSTALLATION GUIDELINES FOR MODELS

SDP303T Whale INSTANT MATCH<sup>®</sup> PREMIUM Kit



For Bluetooth<sup>®</sup> connection to mixer showers use the Instant Match Premium with Whale Sense SDA074T (see Whale Sense Quick Connect Guide included with this kit for more information)

WITH  
**Active Link**



[www.whalepumps.com](http://www.whalepumps.com)

Technical Helpline: 0345 9090 912

**YouTube** [www.youtube.com/WhaleHealthcare](http://www.youtube.com/WhaleHealthcare)

Please leave this booklet with the end user after installation and demonstration

**400,000**  
WHALE KITS INSTALLED IN THE UK





- This appliance may be used by children from 8 years and above, by persons with reduced physical, sensory or mental capabilities and by persons who lack experience of the system, if they have been given instructions concerning the use of the application in a safe way and they understand the hazards involved. Children shall not play with the appliance. Cleaning and user maintenance shall not be carried out by children without supervision.
- If any components or cords are damaged, it must be replaced by a qualified person to avoid a hazard.

## End User Help

### 1. My pump is turning on but not taking the water away

Please contact a plumber to check for blockages, air leaks, and also the condition of the internal rubber components. For video assistance on how to inspect and change the rubber components, please visit [www.whalepumps.com](http://www.whalepumps.com) For further assistance or to request a new tricuspid valve please contact our Technical Helpline on **0345 9090 912**.

### 2. My pump is not working

Please turn on your shower and listen to or feel for vibration of the pump as it starts. If you hear or feel your pump turn on, please contact a plumber to check for blockages or air leaks in the pipework, and the condition of the internal rubber components. For video assistance on how to check the pipework for issues and for a video instructing you how to inspect and change the pump components, please visit [www.whalepumps.com](http://www.whalepumps.com) If your pump doesn't turn on, first check the power is on at the fused spur. If on, please contact an electrician to inspect the power to the pump, or contact our Technical Helpline on **0345 9090 912** for further assistance.

### 3. My Pump is running slow/labouring/cutting out

Contact a plumber to check for blockages. If there are no blockages then contact our Technical Helpline on **0345 9090 912** for further assistance.

### 4. My pump is constantly running

Please contact our Technical Helpline on **0345 9090 912** for further assistance before contacting an electrician to carry out tests on the equipment.

### 5. My pump isn't turning on

If your pump doesn't turn on check that the power is turned on at the fused spur. If on, please contact an electrician to inspect the power to the pump. For further assistance please contact our Technical Helpline on **0345 9090 912**.

### 6 My pump turns on randomly

Please contact a plumber to fit non-return valves to your hot and cold pipework before the flow switches to prevent this from happening.

### 7 How do I register my warranty?

Please complete and return the warranty registration form supplied with your pump, or complete the online form at: [www.whalepumps.com](http://www.whalepumps.com)



0345 9090 912



[info@whalepumps.com](mailto:info@whalepumps.com)



[www.whalepumps.com](http://www.whalepumps.com)



Whale, 2 Enterprise Road,  
Bangor, Co. Down,  
BT19 7TA, N.Ireland

**Thank you for purchasing this Instant Match Premium product.  
Whale® is the market leader in pumped shower drainage kits.  
These kits have the reputation of working reliably for many years  
without requiring maintenance.**

The front cover shows the product installation in an apartment with the components in a concealed access. Assess your installation prior to fitting to ensure that the unit will be situated in an accessible location. Typical installations would have these components in an adjacent cupboard i.e. airing cupboard or in a false wall with an access panel. Do not fit the pump cover in these locations.

**Incorrect installation may invalidate the warranty.**

## Principles of Operation

This kit has been designed for the pumping of shower waste water. The Instant Match Premium control unit uses flow sensors to measure the flow rate of water into the shower. The control unit uses the signals sent from the flow sensors to adjust the pump speed to match the flow of water from the shower. This minimises suction noise at the gulley. When the shower is turned off, the flow sensors send a signal to the control unit and after a pre-set time delay the pump turns off. After a further 15 minutes the pump will automatically switch on for a short period of time at a reduced pumping speed, removing any run off water pooled in the shower area. The pump has the ability to run dry without causing damage. Non-return valves in the pump head prevent smells from entering the bathroom area from the waste pipe.

## Installation Warnings



Before installation please read the instructions. All electrical and mechanical components (Transformer, Pump and Sika® flow sensors) must be accessible after installation.

- The Instant Match Premium is designed to work on shower bases with a minimum of a 1:40 fall to the gulley. Where the fall is insufficient, the water will not refill the gulley rapidly enough and so suction noise will be increased. We recommend the use of a shower former as this eliminates the risks of pooling caused by insufficient fall to the gulley.
- Forming a shower base by hand is a highly skilled task and must be carried out by a trained installer. Do not attempt this if you are unsure and seek professional advice.
- The maximum flow rate of the shower that the pump is designed to work with is 12 ltrs/min.
- Avoid plumbing the pump outlet into the waste piping that other appliances drain into as there is a risk of induced syphoning. Use an anti-syphon trap in these situations. (See page 7)
- In installations where the floor is being formed in the screed, we recommend the following minimum falls: 40mm in 1m, 20mm in 500cm, 10mm in 250cm.
- Plumbing must comply to latest WRAS standards.
- The electrical wiring must conform to wiring regulations BS7671 2018 Part 7 (18th Edition).
- Pipework must be secured to prevent vibration and noise.
- Ensure that the water fall from the shower head is as close to the gulley as possible.

# Index

User warnings	2
End user help	2
Principles of operation	3
Plumbing specification	5
Plumbing gulley	6
Plumbing of waste pipe	7
Installation	8
Transformer settings	13
Swapping pump & transformer on backplate	14
Safety warning	14
Installation testing and repair	15
Declaration of conformity	16
Statement of limited warranty	16
Specification	17
List of parts included in the kit	18
Spare and accessories	18
Fault diagnosis	20/21
Product dimensions	22/23

# Plumbing Specification

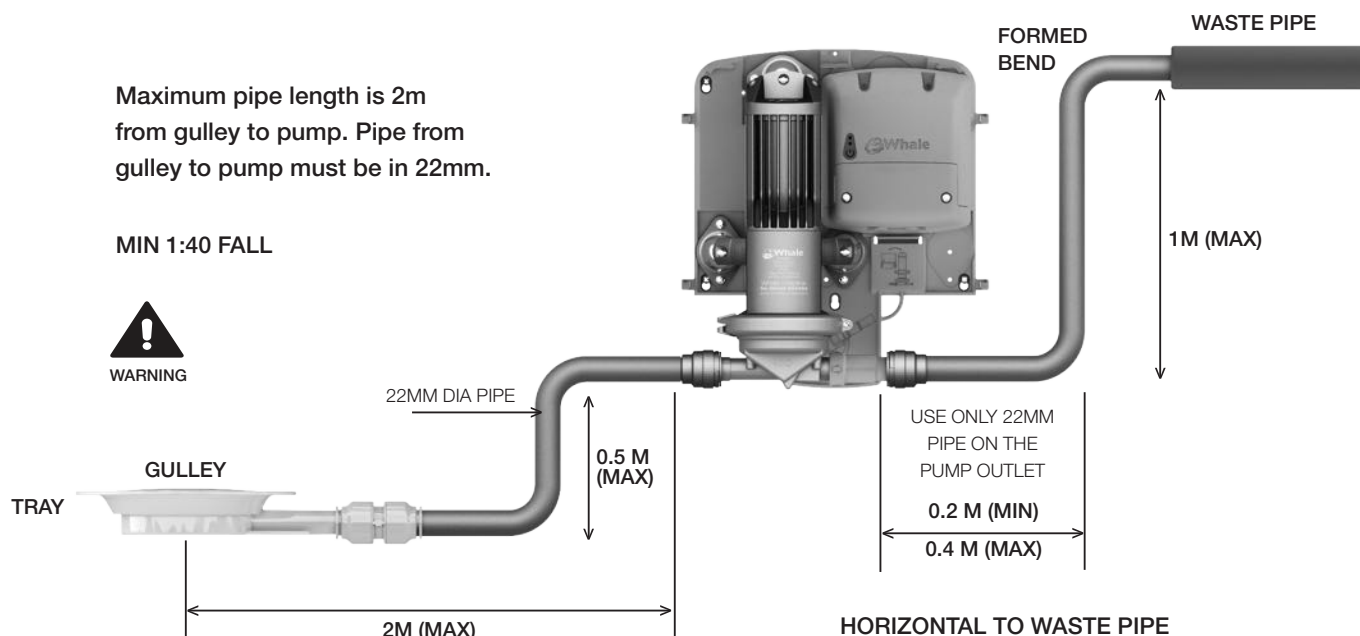

**Fig 1.1**



### HORIZONTAL TO WASTE PIPE

TO INCREASE PUMP LIFE ENSURE THAT 32mm ( 1 1/4" ) or 40mm ( 1 1/2" ) PIPE IS USED WITH A GRAVITY FALL WHERE THE PIPE LENGTH IS GREATER THAN 1M. IF LESS THAN 1M USE 22MM PIPE

- The Whale® pump is IP45 compliant. Locate pump in accordance with BS7671: 2018 Part 7 (18th Edition). The Whale Pump is rated to IP45 and the Whale transformer is rated to IP65. We recommend the pump and transformer are installed in bathroom zones 2 and 3.
- Maximum flow rate 12 ltrs per min.
- Unit and Flow Sensors **MUST BE ACCESSIBLE AFTER INSTALLATION.**
- Only slow radius or pre-formed bends to be used.
- Inserts **MUST NOT** be used with plastic pipe.
- For the flexible pipework included with the kit, use the push fit fittings supplied. Ensure the pipe is pushed fully home into the fittings and secured by fitting the collet clips supplied. For the gully included with the kit, use the push fit fittings supplied. Ensure the pipe is pushed fully home into the fittings and secured by the 'twist lock'. Use silicon spray to aid pipe insertion in order to prevent the 'O' ring being displaced or rolled.
- Ensure that pipe edges are score free. Do not use a hacksaw to cut pipe.
- Use one vertical lift to the pump and one vertical rise from the pump. Pipework must be secured.

- Rotate the pump head if necessary. Loosen clamping ring screw, rotate and retighten as shown. See Fig 1.2
- Before commissioning the shower and running water through the system, ensure that the shower area and gully are completely free of building debris, especially tile grout, screed material and latex.



Fig 1.2



## Plumbing Gully

- Do not use inserts or stem elbows as these restrict flow.
- When fitting in solid floors if copper pipe is used, it must be sheathed to prevent corrosion.
- Orientate gully so that it exits towards the pump inlet to avoid unnecessary bends.

### Wet Floor Gully:

The wet floor gully has a 40mm profile to enable it to fit into a screed floor without penetrating the damp-proof membrane. See Fig 1.3

- Where a floor former is not used, the gully has two lugs either side of the discharge pipe to enable the gully to be fixed to the floor whilst screed is laid.
- Where a floor former is used, these lugs can be easily broken off to enable it to be fitted.
- The gully has a conventional clamping ring to accommodate vinyl flooring.
- Once the area has been cleaned and before the shower is lined, remove dust seal and click cover into place.

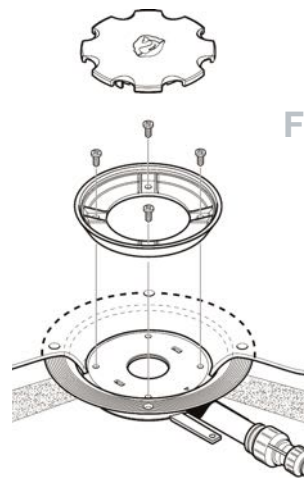
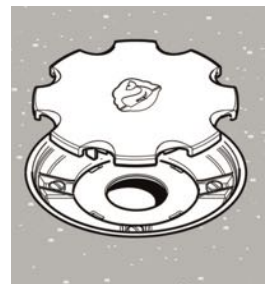

Fig 1.3



### Tray Gully:

The tray gully has a 35mm profile to enable it to fit into a screed floor without penetrating the damp-proof membrane. See Fig 1.4

- Use the hand tool provided to tighten the locking flange and leave it in place to keep debris out of the gully. Only remove it and fit the gully cover when the shower area has been cleaned. See Fig 1.4
- Ensure that the gully debris grid provided is fitted before the shower is used. See Fig 1.4

### Other Gulleys:

The pump kit may be used with linear and traditional gravity gulleys. The gully outlet must be reduced to 22mm to be compatible with the pump.

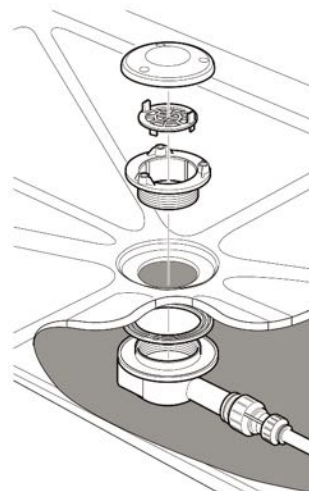
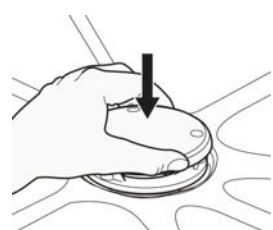
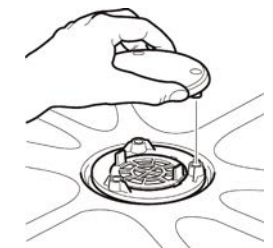
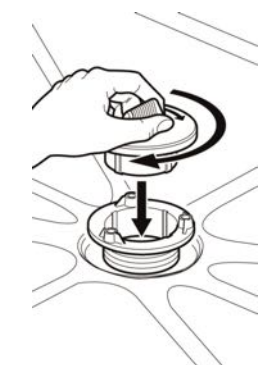

Fig 1.4



## Plumbing of the Waste Pipe

The outlet of the pump can be connected into the waste pipe, e.g. existing bath waste. Black rubber fittings are provided for this.

- In confined bathrooms the pump discharge may go into the sink waste pipe using suitable adaptors. See Fig 1.5 for 32mm (1 1/4") McAlpine examples and the McAlpine catalogue for other variants.

### Use with a Macerator Pump

- Discharge from the Whale® pump must go into the top of the macerator box. Do not use the bottom entries.

### See Fig 1.6

- It is preferable to have two separate discharge lines to waste as any failure of the macerator will not be detected by the Whale pump.

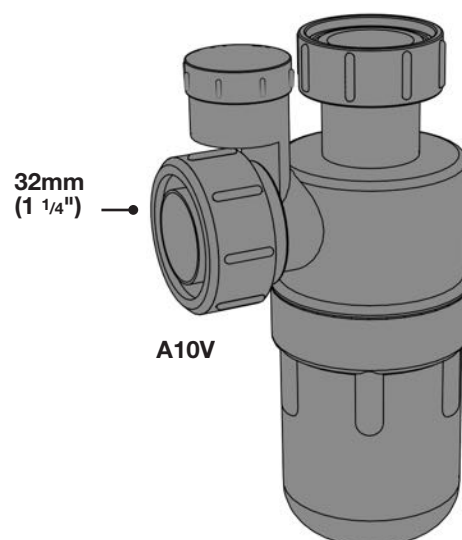
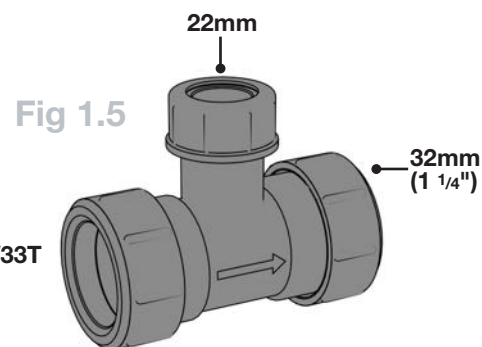
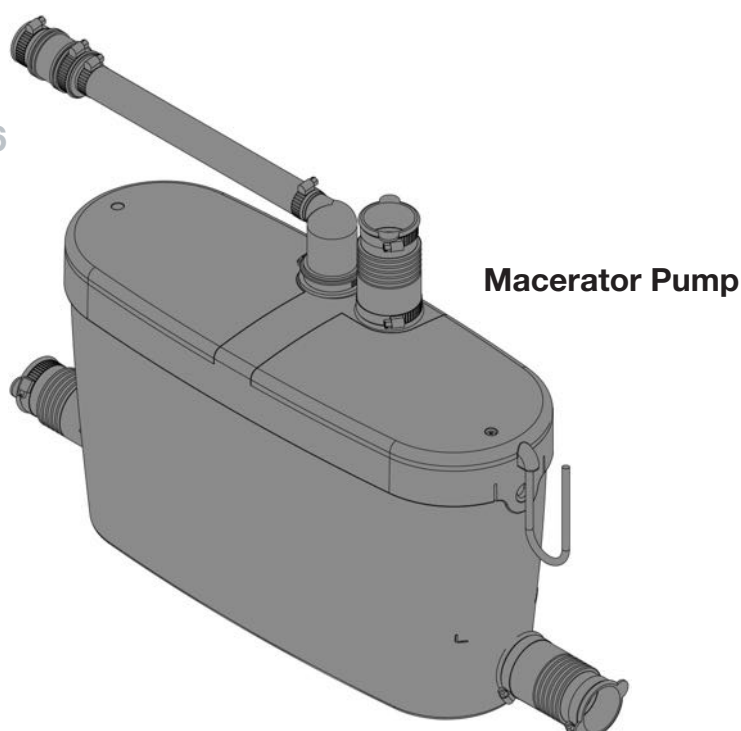

Fig 1.6



# Installation

## 1. Plumbing drainage pipe and hot and cold supplies

- Run 22mm pipe from gully to pump inlet (max 2m).
- Only slow radius or pre-formed bends to be used.
- Sensor provided with 1m of cable. Additional cable purchased separately (part number SDS281T).



## 2. Locating your pump on the wall

- Select a suitable location for the pump, considering the best plumbing option for the pump outlet to discharge into the waste pipe. The pump head may be rotated to the left hand side or right hand side.
- Mount square to wall.
- Using a spirit level ensure that the unit is mounted level.
- Do not install the pump inlet/outlet more than 500mm off the floor.
- NOTE: The pump and transformer mounting location on the backplate may be swapped right to left / left to right. See Page 14 for further information.

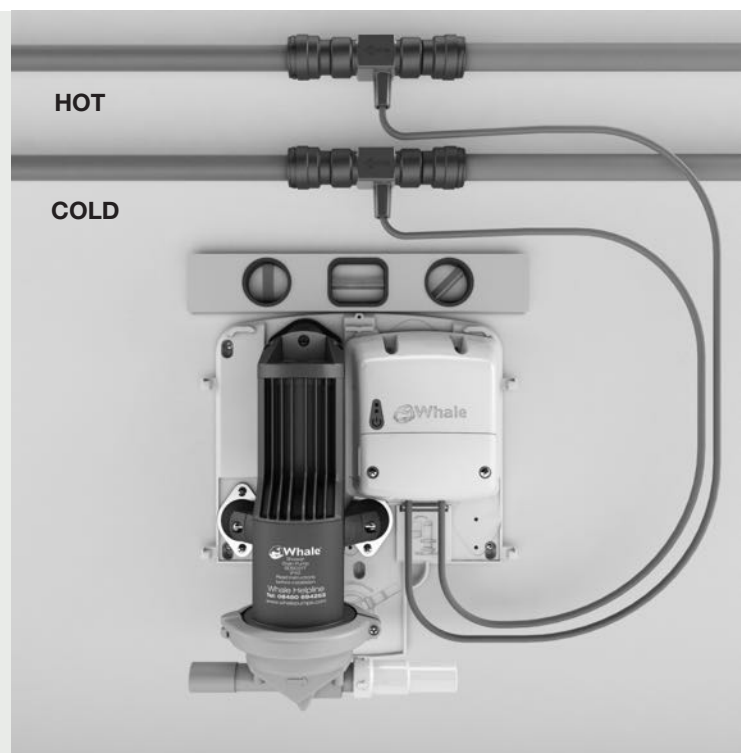



### 3. Mounting your pump to the wall

- Mark the hole centres through unit backplate.
- Drill holes in wall and fit wall plugs (if necessary). Use 6mm masonry bit.
- Secure the backplate to the wall using supplied screws.
- Use screw locations 1,2,3. Locations A and B are optional.

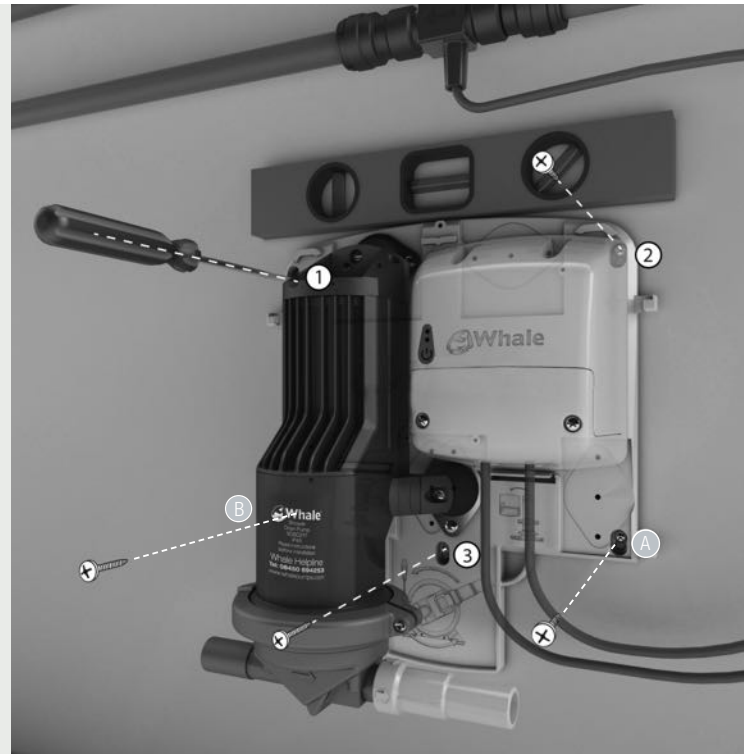

### 4. Plumbing connections

- Push the pipes into the fittings to the full depth of insertion. Secure by fitting collet clips supplied. Use silicone spray to aid pipe insertion in order to prevent the 'O' ring being displaced or rolled.



## 5. Plumbing Sika® Sensors

- Plumb Sika flow sensors to hot and cold supplies with the arrow pointing in the direction of the water flow.
- Do not overtighten the plumbing fittings connected to the Sika flow sensors as doing so may cause leaks.

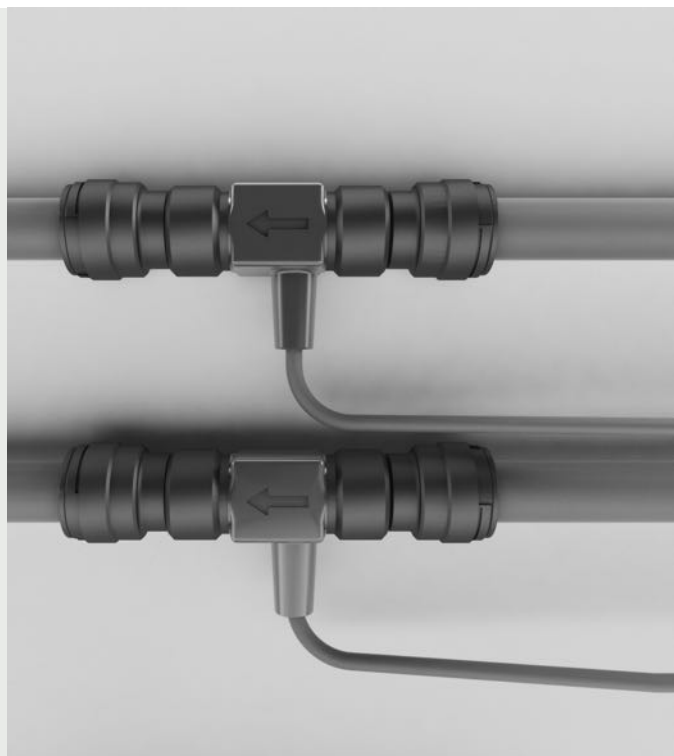

## 6. Wiring your transformer

- Loosen captive screws in hatch and remove as shown.



## 6. Wiring your transformer (continued)

- Connect your sensor to the correct terminal block (see illustration to the right).
- Gently tug on the sensor wires to ensure that there is a secure connection.
- Connect mains wire to a 5A fused spur.
- The transformer is factory set as shown to the right on the jumper settings for the Sika sensors, 30 seconds overrun and 22mm inlet pipe size. For other settings please refer to Transformer settings (see page 13).
- Refit the hatch and tighten the screws to make the transformer water resistant.



## 7. The Whale Instant Match® Premium transformer includes Activelink diagnostics to aid installation:

On the transformer are two indicator LEDs

- The blue LED flashes every 10 seconds indicating that power is on.
- The green LED flashes when water is flowing through the sensors.
- When the test button is depressed the buzzer beeps.

WITH  
**Active Link**



## 8. Regulate your shower flow rate

- Where there is a risk of the flow rate exceeding 12 ltrs per min, the flow regulator must be fitted.
- Fit the internal flow regulator to the shower hose as shown between the mixer bar valve and the shower hose.
- If there is also an overhead shower fitted, install the internal flow regulator as shown.



## 9. Fit and secure pump cover when required to complete set up



## 10. Optional external pump over run switch

Use a retractive switch to briefly activate the pump. This facility is for use when the wet area is being cleaned, or for ritual cleansing. The pump will run for 15 seconds at full speed to clear any water in the showering area. The retractive switch shown is available from Screwfix. (Retractive Switch 1 Gang 1 Way Part No. 6151J)

**NOTE:** This switch may only be fitted outside the wet area.



## 11. Transformer settings

The transformer is factory set for use with Sika flow sensors with a 30 second overrun and 22mm Inlet pipe diameter. Other settings are given below:

### Flow Sensor Type:



- 1 Aux
- 2 Sika (supplied)
- 3 Gems 1000ppl (pulses per litre)
- 4 Gems 2200ppl
- 5 Aux
- 6 Mira Wired
- 7 Aux

For Dip switch settings see Whale website ([www.whalepumps.com](http://www.whalepumps.com))

### Off Delay

- 10s
- 30s
- 60s

### Pipe Inlet Diameter

- 1  15mm inlet pipe (for electric showers only)
- 2  22mm inlet pipe (for mixer showers)



## 12. Purge cycle

- After 15 minutes the transformer will reactivate the pump for 30 seconds at a lower flow rate to remove any run-off or condensation that has collected in the gulley to leave the shower area dry.

### Swapping the Mounting Location of the Pump and Transformer on the Backplate

- Unscrew pump from base.
- Remove the transformer from its secure mounting by pressing the securing tab on bottom of transformer.
- Move the transformer to the opposite side of the casing and place the top two lugs into the spaces provided.
- Click the bottom part of the transformer into place using the securing clip.
- Replace pump in new location and secure with screws.



### Safety Warning



- The transformer is for indoor use only.
- The transformer contains no user serviceable parts.
- External components for service are jumper settings only.
- Where there is damage to the transformer or cabling, contact your Whale distributor for a replacement.
- Do not connect mains power to the pump as this will cause permanent damage and will result in an electrical hazard.
- Installation must conform to BS7671 2018 Part 7 (18th Edition).

# Installation Testing & Repair

The pump system is designed not to require maintenance. If the pump runs but water builds up in the tray, establish the nature of the problem by following the procedure below. This must only be carried out by a qualified contractor.

**TEST PUMP SUCTION** - Remove the pump inlet coupling and press the test button to start the pump. Place a finger in the inlet hole and sense how much the pump is sucking. If strong suction is felt, examine the installation and clear the blockage or check for air leaks as follows.

**RODDING PIPEWORK** - When a blockage is apparent, disconnect the pump from the waste pipe, insert and attempt to push the blockage through the pipe with a separate piece of pipe size smaller than that installed. For example, to rod a 15mm pipe use a 10mm pipe as your rod to clear blockage, and likewise for a 22mm pipe use a 15mm rod. This is an effective way of ensuring any blockage is removed from the waste pipe run. An alternative option for a rod is a 6mm drain rodding spring (if one is available).

**EXTERNAL PIPEWORK TEST** - Make up external pipe work from the pump directly across the bathroom floor and elbow into the gully. Use elbows as required and up to 3m of pipe. See Fig 1.7. Turn the shower on. If water is removed from the tray, then the issue exists in the pipework between the gully and the pump.

**AIR LEAK TEST** - Run a clear tube from the discharge to the sink. If water builds up and fills the gully, yet air is seen in the clear tube on discharge, then the air must be coming from the pipe work. Check and secure all above floor fittings. If these are eliminated investigate the underfloor pipe work by lifting the floor/tray. See Fig 1.7

**FLOW RATE TESTING** - A convenient way to measure the flow rate is to get a 2ltr plastic jug and mark the 2ltr level in black pen. Turn the shower on to where the customer normally uses it - often maximum setting. Put the jug under the shower head and measure how long it takes for the jug to fill to the 2ltr line. Longer than 20 seconds indicates flow rate of less than 6ltrs per minute - typical for electric showers. Shorter than 15 seconds indicates a flow rate of more than 8ltrs per minute - normal for mixers.

**CHECK TRICUSPID VALVE** - Remove the tricuspid valve holder screwed onto the pump discharge. Remove the rubber valve and assess its condition. If it is worn or stiff then change and re-test. It is good practice to replace the tricuspid valve when doing any routine service.

**CHECK INSIDE PUMP HEAD** - Remove the clamping ring and pump head carefully so as not to disturb the seating of the diaphragm. Check that the valves in the pump head are clear of debris. Remove any debris and rinse out the pump head before refitting the pump head and clamping ring. Ensure that the diaphragm bead is not pinched, as this will cause poor pump performance.

If the diaphragm has become unseated, disconnect one low voltage lead at the pump, press the test button and briefly touch the disconnected leads together. This will change the position of the diaphragm. Do this until the diaphragm is at its lowest position. The diaphragm bead will now push easily into the groove on the pump body and the head will also fit easily onto the diaphragm bead without pinching it. Then refit and tighten clamping ring. Check for leaks whilst pump is running.

Spare parts and accessories are listed on Page 18.



Fig 1.7



Scan here to visit  
our troubleshooting  
YouTube site



# Declaration of Conformity

Description of Equipment: Shower Drain System

We hereby declare, under our sole responsibility, that the above product complies with the provisions of the following Directives.

2014/53/EU RED Directive

2014/35/EU Low Voltage Directive

2014/30/EU Electromagnetic Compatibility Directive

Standards applied:

IEC 60335-2-41:2012 Edition 4

IEC 60335-1:2010+AMD1:2013 edition 5.1

EN 60335 2 41:2003 + A1:2004 + A2:2010

EN 60335 1:2012

EMC:

BS EN 55014-1:2006 + A2:2011

BS EN 55014-2:2015

BS EN 61000-3-2:2014

BS EN 61000-3-3:2013

Radio:

EN 301 489-3 v2.1.0

Richard Bovill

Engineering Director

Whale 2 Enterprise Road, Bangor,

Co. Down, BT19 7TA, UK

**Technical Helpline: 0345 9090 912**

**whalepumps.com**

**drainagesupport@whalepumps.com**

**tel: +44 (0)28 9127 0531**

# Statement of Limited Warranty

The products manufactured and supplied by the Company ("Products"), are warranted to be free from material defects in design, workmanship and material under normal use ("Defects") for (unless otherwise extended in advance in writing by the Company) a period of 3 years from date of purchase, save that this warranty shall not apply where the Defect is attributable to defective materials supplied by third parties. In such event, the only remedy of the buyer of the Products ("Buyer") will be against that third party.

This warranty applies only to Products that are properly installed and used in accordance with all oral and written maintenance, installation, and operation instructions provided by the Company. The Company shall not be liable for a breach of any of the warranties in this Statement of Limited Warranty if the Buyer makes any further use of the Products after giving the Company notice of any Defect or the Buyer alters or repairs such Products without the written consent of the Company. Products that have been disassembled or modified (without prior written approval of the Company), are not covered by this warranty. All Products are covered by a 3 year limited warranty (detailed below) from (unless otherwise extended in advance in writing by the Company) date of purchase ("Standard Warranty").

In addition to the Standard Warranty, these Products will be covered by a further warranty of 2 years but only when the registration form is completed and returned ("Additional Warranty"). The period of such Additional Warranty shall commence automatically the date the Standard Warranty expires.

In the event that any of the warranties offered by the Company are breached, the Company shall (at its discretion) repair, replace or issue a spares kit for the defective Product subject to prior examination at Company premises.

If the Company complies with this paragraph, it shall have no further liability for a breach of the warranties in respect of such Products. Adjustment or replacement of defective parts made under this warranty will not extend the warranty period applicable either under the Standard Warranty and/or the Additional Warranty.

The Company shall not bear any costs of removal, installation, transportation, or other charges that may arise in connection with a warranty claim by the Buyer. Such costs shall be the Buyer's sole responsibility.

No claim in respect of defective Products will be valid unless the alleged defective Products are returned at the Buyer's expense to the Company for inspection, together with proof of purchase.



# Specification

## Pump

- Model: SDS021T
- Dry running current: 1.2 amp
- Maximum Head: 1.0m
- Maximum lift: 500mm
- Maximum Head & Lift: 1.5m
- IP45

## Transformer

- Model: SDS236T
- 75 Watts average
- Class 1
- Mains cable 1.8m (3 core)
- Low voltage cable 2.0m (2 core)
- Sensor type selector
- Off Delay of 10, 30 and 60 seconds
- IP65

©Copyright Whale 2023 - All rights reserved.

**Reproduction in whole or in part without permission is prohibited.**

WHALE<sup>®</sup> and WHALE INSTANT MATCH<sup>®</sup> are registered trademarks of Munster Simms Engineering Limited, Bangor, Northern Ireland trading as Whale. Whale's policy is one of continuous improvement and we reserve the right to change specifications without prior notice. Illustrations are for guidance purposes only. Neither the accuracy nor completeness of the information contained in any product literature is guaranteed by the Company and may be subject to change at its sole discretion.

SIKA<sup>®</sup> symbol is a registered trade mark of Dr. Siebert & Kuhn GmbH & Co. KG

The Bluetooth<sup>®</sup> word mark and logos are registered trademarks owned by Bluetooth SIG, Inc. and any use of such marks by Munster Simms Engineering Ltd (trading as Whale) is under licence. Other trademarks and trade names are those of their respective owners.

Subject to the remaining provisions of this Statement of Limited Warranty, the Company's total liability in contract, tort (including negligence or breach of statutory duty), misrepresentation, restitution or otherwise, arising in connection with the performance or contemplated performance of the Contract and supply of the Products shall be limited to the Contract price. Nothing in this Statement of Limited Warranty shall operate so as to exclude or restrict the Company's liability for death or personal injury caused by its negligence.

The Company shall NOT be liable for any condition, warranty or representation made by a distributor or other person acting on behalf of the Company unless expressly confirmed by the Company in writing.

This Statement of Limited Warranty shall be governed and construed in accordance with Northern Irish law and all disputes arising in connection hereto shall be submitted to the exclusive jurisdiction of the Northern Irish Courts.

Any performance / specification figures shown have been calculated using standard testing procedures. Where maximum output is stated, such maximum output refers to pumps acting at zero lift and zero head. Actual performance may vary depending on the application, installation and environmental factors. Neither the accuracy nor completeness of the information contained in any Product brochure is guaranteed by the Company and may be subject to change at its sole discretion. The Company may, at its sole discretion, change the technical performance, dimensions or appearance of any of its Products without prior notification to purchasers. The Company shall not be liable to a purchaser for any indirect or consequential loss or damage (whether for loss of profit, loss of business, depletion of goodwill or otherwise), costs, expenses or other claims for consequential compensation whatsoever (howsoever caused) which arise out of or in connection with the use of a Product. Where dimensions are stated, such dimensions are for guidance only. Inch measurements are conversions from millimetre dimensions and are shown to the nearest 1/16". US gallons volumes are conversions from litres and are also shown for guidance purposes only to the nearest 1/16. Please contact the Company directly if precise measurements are required.

## List of Parts included in the kit

Item	Part No.	Qty
Shower Drain Pump	SDS021T	1
Transformer Instant Match Premium	SDS233T	1
Pump Cover base	755.610	1
Pump Cover (for mixer)	SDS261T	1
Wet Floor Gulley (vinyl floors)	755.274	1
Sika Sensor	SDS263T	2
10 ltrs per min flow regulator	SDS201T	2
Tricuspid valve	755.57	1
5mtr Length Sika cable	755.605	2
Rubber Waste adapter 2 parts		
22mm – 1½" fitting		1
22mm – 22mm fitting		1
Anti-vibration hoses (pair)	SDS241T	1

## Spares and Accessories

These additional parts may be ordered from your distributor

Description	Part No.
90mm Gulley	AK1695
Sika flow sensor	SDS263T
Shower Drain Pump	SDS021T
Instant Match Transformer	SDS236T
Tricuspid Valve (Qty 10)	SDS211B
Pump head replacement kit	SDS071T
Diaphragm and Tricuspid kit	SDS061T
10 ltrs per min flow regulator	SDS201T
5mtr cable and 3 way conx block	SDS281T

Note: Standard gravity gulleys may be used with the Instant Match Premium kit. Reduce the outlet to 22mm for compatibility with pump.

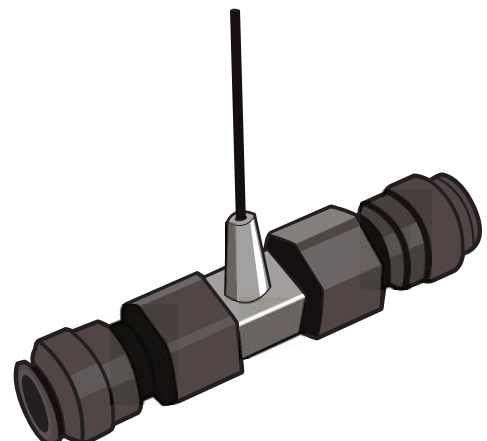
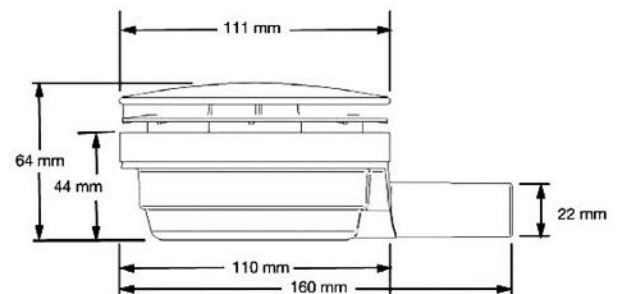

Sika flow sensor SDS263T

## Pump Base Standoffs

Where pipe runs make installation of the pump base difficult we recommend the use of a Space - Plug (Available from SCREWFIX Version 30-50mm shown below)

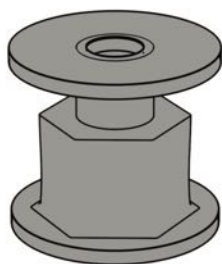

# INSTANT MATCH Kit Fault Diagnosis

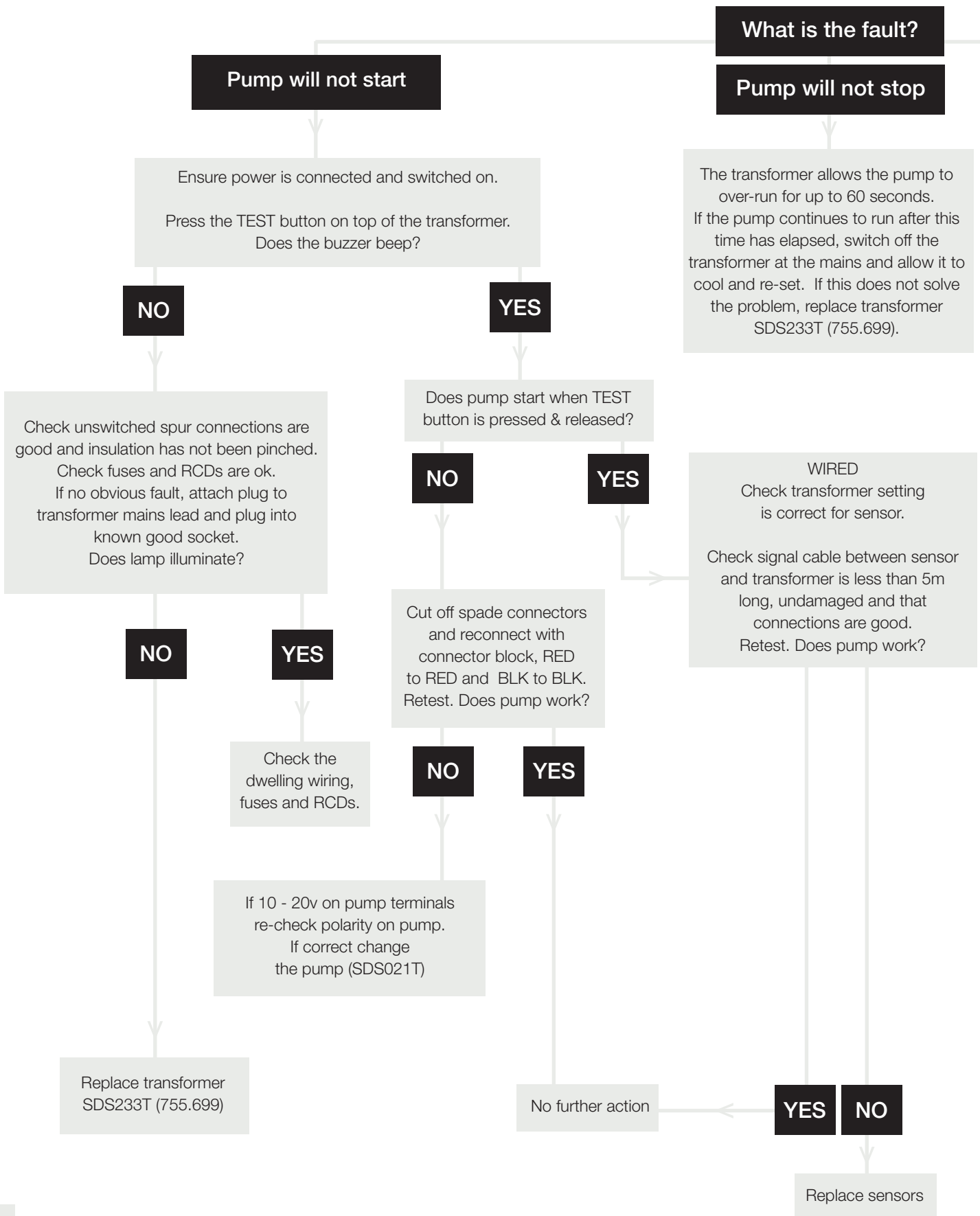

**Pump does not pump properly**

Ensure that the gulley is not blocked and that fittings are pushed home and airtight.  
 Re-test and if pump does not pump properly, remove inlet coupling and press the test button on the transformer, or run the shower into the sink to run the pump.  
 Place a finger over the pump inlet.  
 Is strong suction felt?

**NO**

Inspect that the tricuspid valve inside the screw on holder on the pump discharge is in good condition and that couplings and discharge pipework are clear of debris or blockages.

If these are OK remove and inspect the pump head as described in the Installation & Repair section of these instructions.

Take care to confirm that flap valves close properly and that the diaphragm bead has not been squashed.

These parts are available in the Replacement Head Kit (SDS071T) – includes diaphragm and tricuspid.  
 or  
 Replacement Diaphragm and Tricuspid Kit (SDS061T)

**YES**

Check flow rate of shower.  
 On 22mm inlet pipe.  
 Max flow 12 ltrs/min

If OK see below.

Check for blockages on inlet and outlet pipe and for air leaks as described in the Installation Testing and Repair section of these instructions.

Repair any leaks or clear blockages.  
 Once the problem has been resolved it is good practice to replace the tricuspid valve.

These are available in packs of 10 - SDS211B

# Plumbing Specification

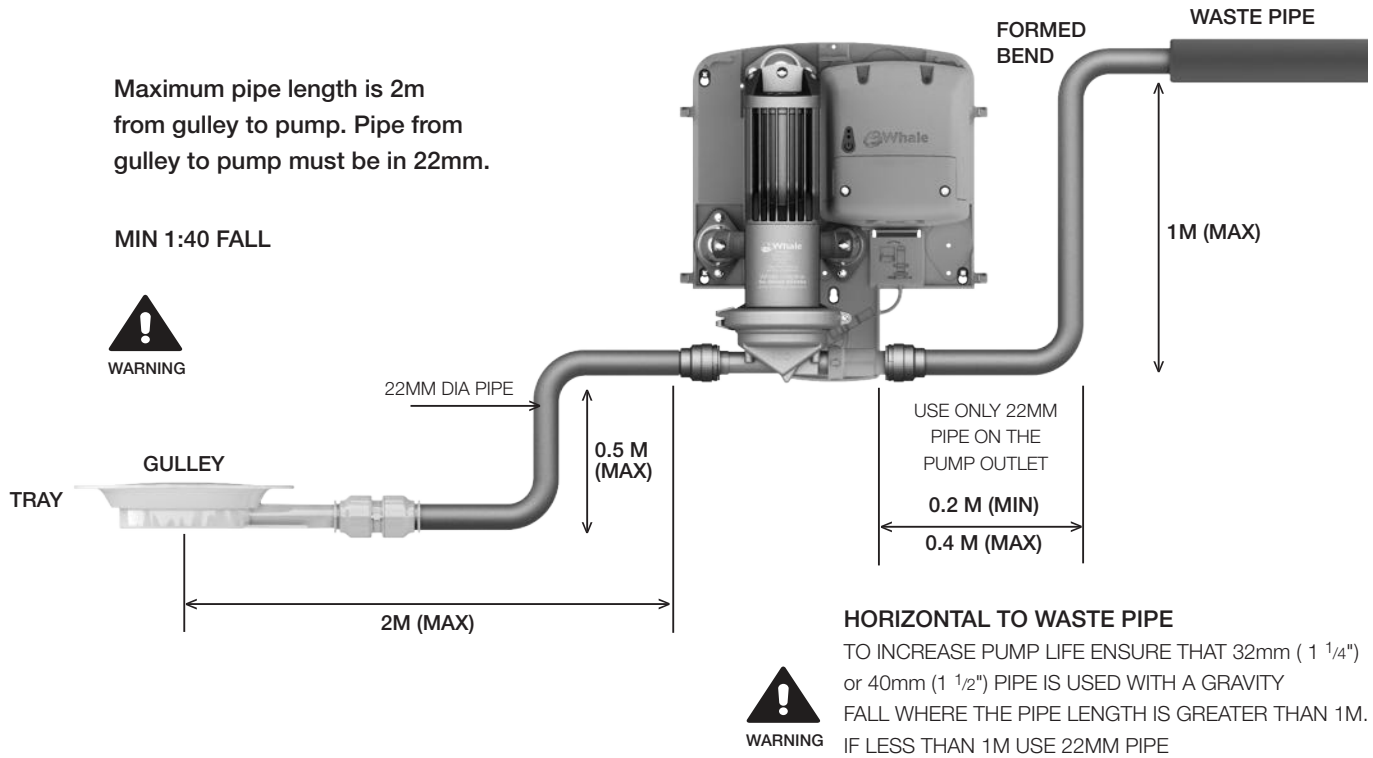

## Pump Cover

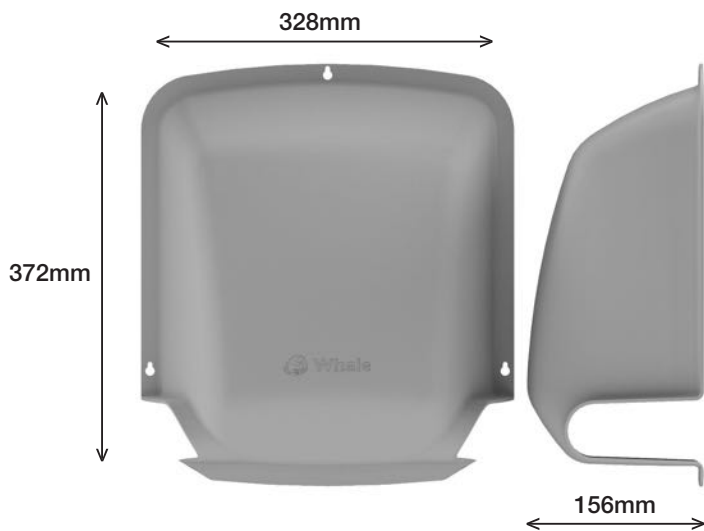

## Transformer

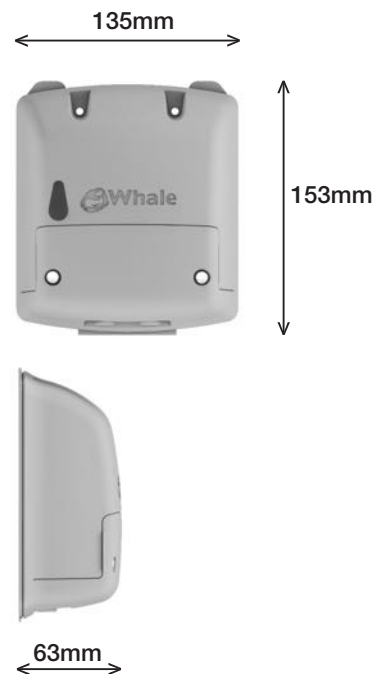

# Pump - SDS021T

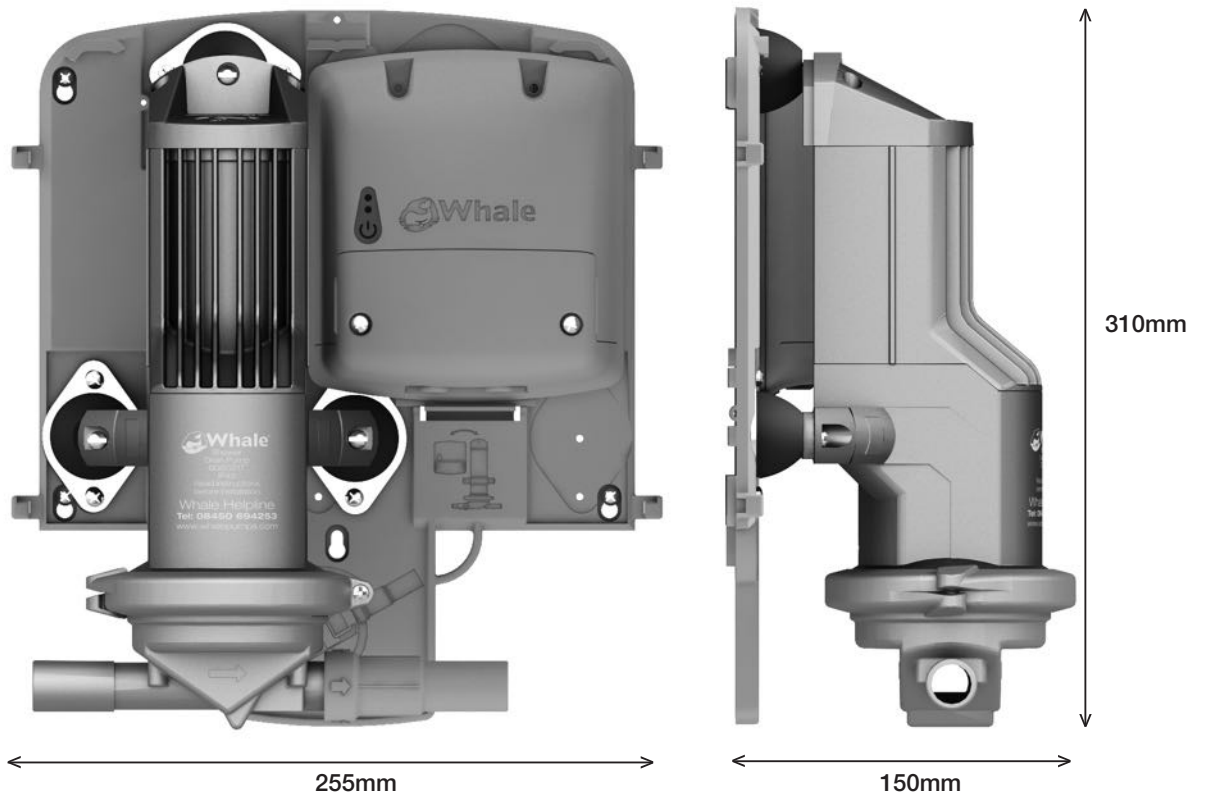

Contact the Technical Helpline  
If you need further assistance:

**0345 9090 912**



0345 9090 912



[drainagesupport@whalepumps.com](mailto:drainagesupport@whalepumps.com)



[www.whalepumps.com](http://www.whalepumps.com)



**Whale, 2 Enterprise Road,  
Bangor, Co. Down,  
BT19 7TA, N.Ireland**